

Schematic Diagram of JumboZ-300 MANUAL STEERING

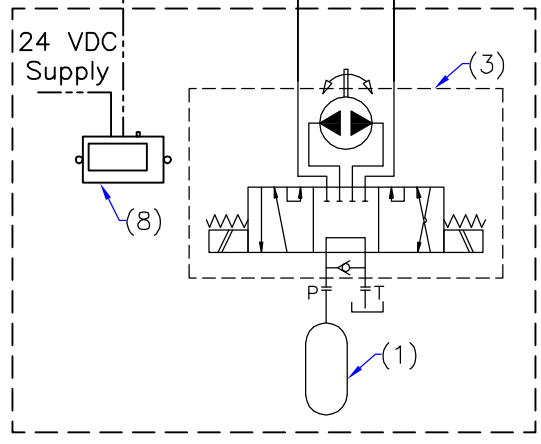
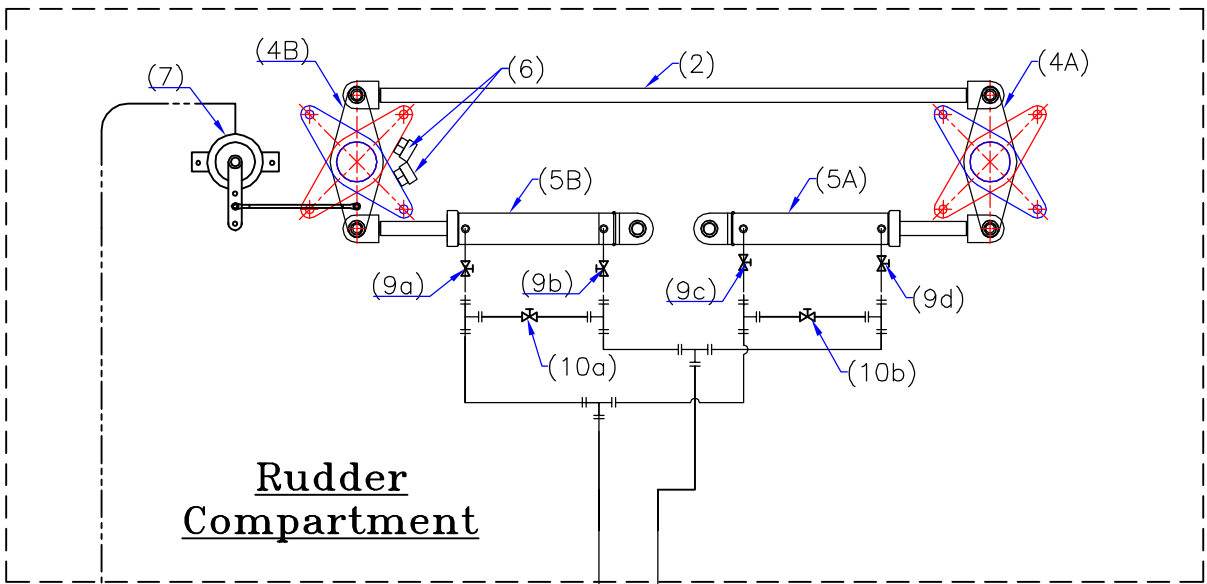

10a,10b	By-Pass Valve
9a,9b,9c,9d	Isolation Valve
8	Rudder Angle Indicator
7	Rudder Angle Sensor
6	Mechanical Stopper (Customer Supply)
5a,5b	Hyd. Actuator
4a,4b	Tiller Arm
3.	Main Steering Unit
2.	Connection Rod (Customer Supply)
1.	Oil Reservoir
Sl.no	Description

SPECIFICATIONS	
1.	Tiller Radius : 180mm.
2.	Pump Capacity:- Manual : 80CC/rev.
3.	HYD.ACTUATOR:- Ram : 30 mm x 2 Stroke : 260 mm.
4.	PIPE :- OD : 16mm. ID : 12MM.
5.	HOSE :- GRADE : R1 I.D : 1/2"

ITEM	SCALE	MATERIAL	VIEW	DRAWN	CHECKED
/	NTS	/		JK	VUK
DESIGNATION			DWG NO	DATE	QTY
Schematic Diagram of JumboZ-300M			MHS-1200	10.12.2020	/
MAC ♦ N ♦ HOM SYSTEMS KOCHI - 20					